

**North American Electric, Inc.**

"Your Source for a Complete Line of Electric Motors"

## **VERTICAL HOLLOW SHAFT MOTORS**

- **10 – 500 HP, 1800 RPM**
- **High Torque/High Thrust Design**
- **Cast Iron Construction**
- **Open Dripproof (WP-1) Enclosure**
- **Special Builds and Modifications Available**



**DESIGNED SPECIFICALLY FOR  
DEEP WELL TURBINE PUMPS**

## **Mission Statement**

To provide the United States market for industrial motors and controls with products which meet or exceed customer expectations for quality, performance, and reliability at the lowest possible cost and delivered in accordance with the customer's schedule, through our authorized distributor network.

## **Company History**

North American Electric, Inc. is a wholesale supplier of Special Purpose and General Purpose, AC electric motors and controls. We take pride in supplying high performance, high quality products at extremely competitive prices throughout the United States. Donald E. Hackman, Sr. and David E. Hackman founded the company in October of 1993. The company's primary focus is sourcing quality electric motors from various manufacturers, both locally and internationally, and distributing them throughout the United States through local distributors and service centers. Our nationwide distributor and service network offer strong local support for our products by providing critical logistical, technical and maintenance support as well as fast, friendly customer service.

## **WARRANTY POLICY**

All motors sold by North American Electric, Inc. are warranted to be free from defects in material and workmanship. The warranty is 24 months from the date of manufacture but no less than 18 months from date of invoice. Also, all motors installed within 24 months from date of manufacture will be warranted for no less than 12 months from the date the motor is installed. North American Electric, Inc. shall, at its option and expense, either repair or replace any such motor or part, which is defective within the warranty period. To be covered under warranty, any motor must have at all times been operated or used under normal operating conditions for which the motor was designed.

In the event of warranty claims, North American Electric, Inc. must be notified promptly following any motor failure. The motor should be sent to a North American Electric, Inc. authorized service center to diagnose the cause of failure. After this examination, a determination will be made if the failure was due to defective material and/or workmanship. If the failure was due to defective material and/or workmanship, North American Electric, Inc. will replace or repair the motor.

North American Electric's liability under this warranty or any other warranty whether expressed or implied in law or fact shall be limited to the repair or replacement of defective material and workmanship, and in no event shall North American Electric, Inc. be liable for consequential or indirect damages, including freight.

**YOUR SOURCE FOR A COMPLETE LINE OF ELECTRIC MOTORS !!!**

	<p><b><u>SINGLE PHASE, 56C FRAME, TEFC</u></b>  <b>1/3-2 HP 2,4 POLE</b>            HIGH STARTING TORQUES MANUAL OVERLOAD PROTECTION (OPTIONAL)            CAPACITOR START / CAPACITOR RUN DESIGN            ROLLED STEEL FRAME CONSTRUCTION IP55 PROTECTION-REMOVABLE FEET</p>		<p><b><u>HIGH EFFICIENCY PLUS, SEVERE DUTY, INVERTER RATED</u></b>  <b>20-500 HP 2,4,6,8 POLE</b>            HIGH EFFICIENCY "PLUS" DESIGN (EXCEEDS EPACT '92 &amp; NRCAN EFFICIENCY REQ.)            ALL CAST IRON FRAME CONSTRUCTION DESIGNED FOR EXTREME HARSH ENVIRONMENTS            INVERTER RATED (10:1 VARIABLE TORQUE; 5:1 CONSTANT TORQUE)</p>
	<p><b><u>SINGLE PHASE, FARM DUTY, TEFC</u></b>  <b>1/3-10 HP 4 POLE</b>            HIGH STARTING TORQUES MANUAL OVERLOAD PROTECTION (1/3 THRU 5 HP)            CAPACITOR START / CAPACITOR RUN DESIGN            ROLLED STEEL FRAMES CAST IRON ENDBELLS</p>		<p><b><u>NEMA PREMIUM EFFICIENCY INVERTER DUTY MOTORS</u></b>            MEETS OR EXCEEDS NEMA PREMIUM EFFICIENCY LEVELS QUALIFIES FOR ENERGY EFFICIENCY REBATES</p>
	<p><b><u>SINGLE PHASE OPEN DRIPPROOF</u></b>  <b>3,5 HP 4 POLE</b>            HIGH STARTING TORQUES            CAPACITOR START / CAPACITOR RUN DESIGN            ROLLED STEEL FRAME CONSTRUCTION CAST IRON ENDBELLS</p>		<p><b><u>CRUSHER DUTY MOTORS</u></b>  <b>1-500 HP 4,6,8 POLE</b>            NEMA DESIGN C HIGH STRENGTH 4140 GRADE STAINLESS STEEL SHAFT            586/7U FRAME HEAVY DUTY CAST IRON CONSTRUCTION (INCLUDING FAN COVER)            BEARING SIZES: DE=NU324 ODE=6324</p>
	<p><b><u>THREE PHASE, 56C FRAME, TEFC</u></b>  <b>1/3-3 HP 2,4 POLE</b>            HIGH EFFICIENCY DESIGN GENERAL PURPOSE MOTORS            ROLLED STEEL FRAME CONSTRUCTION, ALUMINUM ENDBELLS            IP55 PROTECTION REMOVABLE FEET</p>		<p><b><u>EXPLOSION PROOF MOTOR</u></b>  <b>1-300 HP 2,4,6 POLE</b>            ALL MOTORS MEET OR EXCEED UL 674 SPECIFICATION AS REQUIRED BY OSHA FOR INSTALLATION AND USE IN HAZARDOUS LOCATIONS.            CLASS I, DIVISION I, GROUPS C&amp;D AND CLASS II, DIVISION I, GROUPS E,F AND G            UL CERTIFIED - FILE E228654            CSA + "C" + "US" - CANADIAN STANDARD ISO9001</p>
	<p><b><u>THREE PHASE, TEFC ROLLED STEEL MOTORS</u></b>            HIGH EFFICIENCY DESIGN-GENERAL PURPOSE, LIGHT WEIGHT ROLLED STEEL FRAME</p>		<p><b><u>OIL WELL PUMP MOTORS, TEFC</u></b>  <b>3-150 HP 6 POLE</b>            NEMA DESIGN D HIGH SLIP(5% TO 8% SLIP) SPECIAL PURPOSE OIL WELL PUMP MOTORS            HEAVY DUTY CAST IRON FRAME CONSTRUCTION</p>
	<p><b><u>THREE PHASE OPEN DRIPPROOF</u></b>  <b>1-15 HP 2,4 POLE</b>            HIGH EFFICIENCY DESIGN GENERAL PURPOSE MOTORS            ROLLED STEEL FRAME CONSTRUCTION, CAST IRON ENDBELLS</p>		<p><b><u>ALUMINUM MOTORS</u></b>  <b>1-10 HP 2,4 POLE</b>            HIGH EFFICIENCY DESIGN GENERAL PURPOSE, THREE PHASE, TEFC MOTORS            LIGHT WEIGHT ALUMINUM FRAME</p>
	<p><b><u>STAINLESS STEEL WASHDOWN DUTY MOTORS</u></b>  <b>1/3 HP - 20HP 2,4,6 POLE</b>            IP 67 PROTECTION            INVERTER DUTY</p>		<p><b><u>VERTICAL HOLLOW SHAFT PUMP MOTORS</u></b>  <b>10 HP - 250 HP, 4 POLE</b>            HIGH TORQUE - HIGH THRUST</p>
	<p><b><u>HIGH EFFICIENCY, CAST IRON, TEFC, HOSTILE DUTY</u></b>  <b>1-500 HP 2,4,6,8 POLE</b>            HIGH EFFICIENCY DESIGN GENERAL PURPOSE MOTORS            CAST IRON FRAME CONSTRUCTION (INCLUDING CONDUIT BOX)</p>		<p><b><u>ELECTRIC MOTOR CONTROL</u></b>            FULL VOLTAGE STARTERS            SOFT STARTS            INVERTERS            PUMP PACKAGES</p>
			<p><b><u>MOTOR SLIDE BASES</u></b>            AVAILABLE 56C THRU 505U</p>

# VERTICAL HOLLOW SHAFT MOTOR

*"Buy on Value Not on Price"*



- **10 – 500 HP, 1800 RPM**
- **High Torque/High Thrust Design**
- **Cast Iron Construction**
- **Open Dripproof (WP-1) Enclosure**
- **Special Builds and Modifications Available**

**AC Inverter Rated  
10:1 Variable Torque**

**High torque/High Thrust Design**

**Ball Bearing  
Type Non-Reverse  
Ratchet Included**

**Cast Iron  
Construction**

**Oversized Angular  
Contact Bearing  
and Ball Bearing**

**Light Weight Hood  
for Easy Access**

**Large Reservoir  
"Oil Bath"**

**Oversized Cast  
Iron Conduit Box**

**Space Heaters  
as Standard**

**Thermal Protection  
as Standard**

**Open Dripproof  
(WP-1) Enclosure**

**Mounting Base  
Designed for  
Easy Installation**

**Class F Insulation  
System with VPI  
Class H Impregnation  
Resin**

## **APPLICATIONS:**

**Designed Primarily for Deep Well Turbine Pump Applications. The Coupling is Equipped with a Non-Reverse Ratchet, Which Prevents Motor Rotation from Backspin at Shut Down. These Motors are Built to NEMA Standards and have Special Bearing Arrangements to Carry Heavy Thrust Loads.**

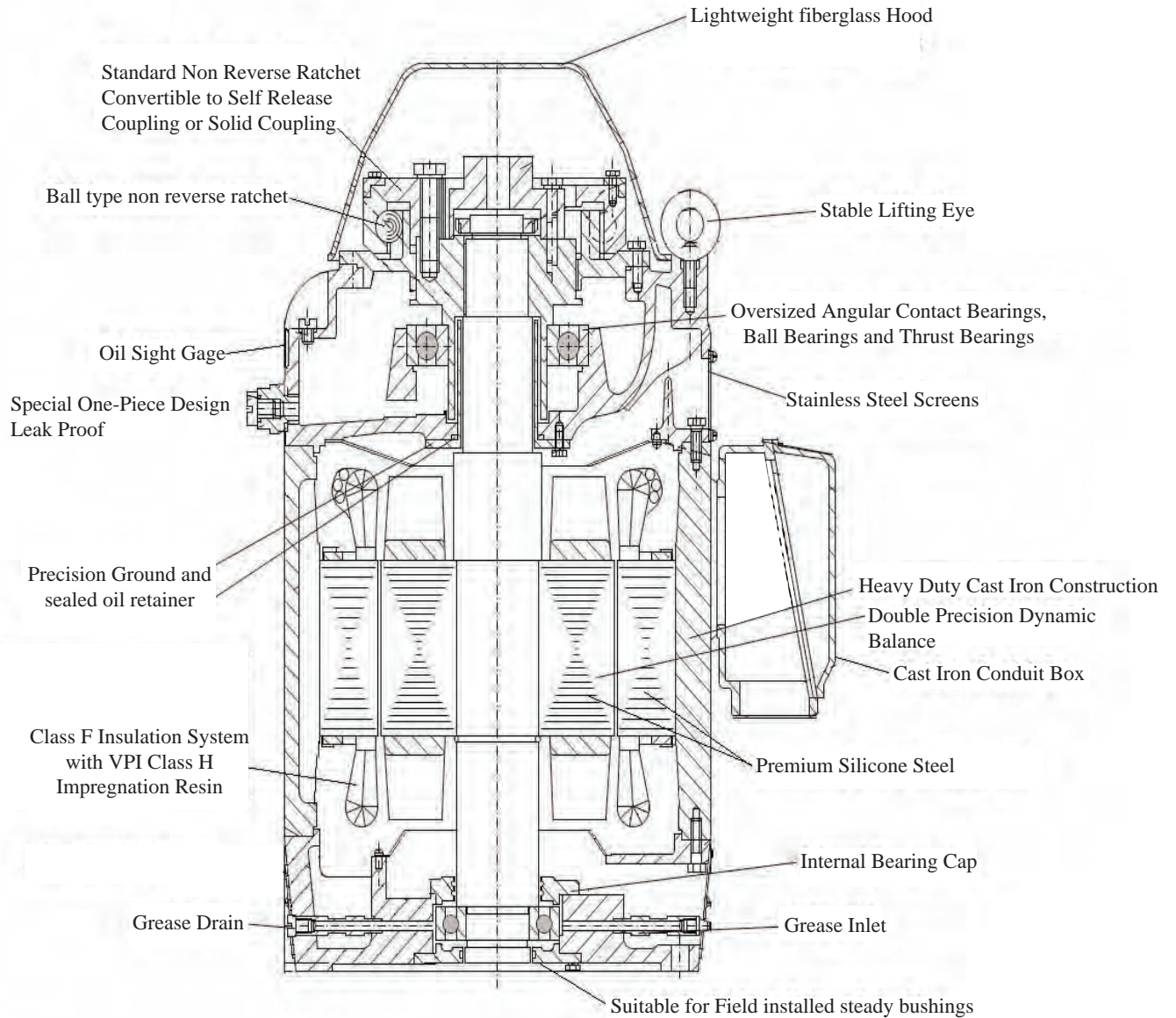

# VERTICAL HOLLOW SHAFT MOTOR PRICING

HP	Frame	Volts	Model #	Price	Notes
10	215TP	230/460	NAEVHS-10-4	\$2,323	
15	254TP	230/460	NAE-VHS-15-4	\$2,998	
15	254TP	230/460	NAE-VHS-15-4-B	\$2,998	2
20	256TP	230/460	NAE-VHS-20-4	\$3,294	
20	256TP	230/460	NAE-VHS-20-4-B	\$3,294	2
25	284TP	230/460	NAE-VHS-25-4	\$3,740	
25	284TP	230/460	NAE-VHS-25-4-B	\$3,740	2
30	286TP	230/460	NAE-VHS-30-4	\$4,035	
30	286TP	230/460	NAE-VHS-30-4-B	\$4,035	2
40	324TP	230/460	NAE-VHS-40-4	\$5,250	
40	324TP	230/460	NAE-VHS-40-4-B	\$5,250	2
50	326TP	230/460	NAE-VHS-50-4	\$5,925	
50	326TP	230/460	NAE-VHS-50-4-B	\$5,925	2
60	364TP	230/460	NAE-VHS-60-4	\$6,650	
60	364TP	230/460	NAE-VHS-60-4-B	\$6,650	2
60	364TP	460	NAE-VHS-60-4-460V	\$6,650	1
75	365TP	230/460	NAE-VHS-75-4	\$7,950	
75	365TP	230/460	NAE-VHS-75-4-B	\$7,950	2
75	365TP	460	NAE-VHS-75-4-460V	\$7,950	1
100	404TP	230/460	NAE-VHS-100-4	\$9,750	
100	404TP	230/460	NAE-VHS-100-4-B	\$9,750	2
100	404TP	460	NAE-VHS-100-4-460V	\$9,750	1
125	405TP	460	NAE-VHS-125-4	\$11,200	
150	444TP	460	NAE-VHS-150-4	\$13,200	
200	445TP	460	NAE-VHS-200-4	\$19,600	
250	445TP	460	NAE-VHS-250-4	\$23,000	
300	5006P	460	NAE-VHS-300-4	\$25,560	3
350	5006P	460	NAE-VHS-350-4	\$29,520	3
400	5008P	460	NAE-VHS-400-4	\$33,475	3
450	5008P	460	NAE-VHS-450-4	\$37,135	3
500	5008P	460	NAE-VHS-500-4	\$40,800	3

**Notes:**

- 1.) 12 Lead - Suitable for Part Wind Start at 460V.
- 2.) Comes with 1.188" coupling installed. (Subject to availability)
- 3.) Heavy guage rolled steel construction.

# VERTICAL HOLLOW SHAFT MOTOR COUPLINGS

HP	Frame	Model Number	Standard	Option	Nominal BX	SQ Key (EW)	List Price
10	215TP	VC210-.750		x	0.750	0.188	\$110
10	215TP	VC210-1.00	x		1.000	0.250	
10	215TP	VC210-.875		x	0.875	0.188	
10	215TP	VC210-BLANK		x	0.000	0.000	
15-20	254TP-256TP	VC250-1.00	x		1.000	0.250	\$115
15-20	254TP-256TP	VC250-.875		x	0.875	0.188	
15-20	254TP-256TP	VC250-.750		x	0.750	0.188	
15-20	254TP-256TP	VC250-1.188		x	1.188	0.250	
15-20	254TP-256TP	VC250-1.25A		x	1.250	0.250	
15-20	254TP-256TP	VC250-1.25B		x	1.250	0.375	
15-20	254TP-256TP	VC250-BLANK		x	0.000	0.000	
25-30	284TP-286TP	VC280-1.00	x		1.000	0.250	\$115
25-30	284TP-286TP	VC280-1.188		x	1.188	0.250	
25-30	284TP-286TP	VC280-1.25A		x	1.250	0.250	
25-30	284TP-286TP	VC280-1.25B		x	1.250	0.375	
25-30	284TP-286TP	VC280-.750		x	0.750	0.188	
25-30	284TP-286TP	VC280-.875		x	0.875	0.188	
25-30	284TP-286TP	VC280-BLANK		x	0.000	0.000	
40-50	324TP-326TP	VC320-1.00		x	1.000	0.250	\$124
40-50	324TP-326TP	VC320-1.188		x	1.188	0.250	
40-50	324TP-326TP	VC320-1.25A	x		1.250	0.250	
40-50	324TP-326TP	VC320-1.25B		x	1.250	0.375	
40-50	324TP-326TP	VC320-1.438		x	1.438	0.375	
40-50	324TP-326TP	VC320-1.500		x	1.500	0.375	
40-50	324TP-326TP	VC320-BLANK		x	0.000	0.000	
60-75	364TP-365TP	VC360-1.00		x	1.000	0.250	\$144
60-75	364TP-365TP	VC360-1.188		x	1.188	0.250	
60-75	364TP-365TP	VC360-1.25A	x		1.250	0.250	
60-75	364TP-365TP	VC360-1.25B		x	1.250	0.375	
60-75	364TP-365TP	VC360-1.438		x	1.438	0.375	
60-75	364TP-365TP	VC360-1.500		x	1.500	0.375	
60-75	364TP-365TP	VC360-BLANK		x	0.000	0.000	
100-125	404TP-405TP	VC400-1.188		x	1.188	0.250	\$165
100-125	404TP-405TP	VC400-1.25A		x	1.250	0.250	
100-125	404TP-405TP	VC400-1.25B		x	1.250	0.375	
100-125	404TP-405TP	VC400-1.438		x	1.438	0.375	
100-125	404TP-405TP	VC400-1.50	x		1.500	0.375	
100-125	404TP-405TP	VC400-1.563		x	1.563	0.375	
100-125	404TP-405TP	VC400-1.688		x	1.688	0.375	
100-125	404TP-405TP	VC400-1.813		x	1.813	0.375	
100-125	404TP-405TP	VC400-BLANK		x	0.000	0.000	
150-200	444TP-445TP	VC440-1.438		x	1.438	0.375	\$275
150-200	444TP-445TP	VC440-1.500		x	1.500	0.375	
150-200	444TP-445TP	VC440-1.688	x		1.688	0.375	
150-200	444TP-445TP	VC440-1.750		x	1.750	0.375	
150-200	444TP-445TP	VC440-1.938		x	1.938	0.500	
150-200	444TP-445TP	VC440-2.188		x	2.188	0.500	
150-200	444TP-445TP	VC440-BLANK		x	0.000	0.000	
250	444TP-445TP	VC440-1.438		x	1.438	0.375	\$275
250	444TP-445TP	VC440-1.500		x	1.500	0.375	
250	444TP-445TP	VC440-1.688		x	1.688	0.375	
250	444TP-445TP	VC440-1.750		x	1.750	0.375	
250	444TP-445TP	VC440-1.938	x		1.938	0.500	
250	444TP-445TP	VC440-2.188		x	2.188	0.500	
250	444TP-445TP	VC440-BLANK		x	0.000	0.000	

# VERTICAL HOLLOW SHAFT MOTOR ACCESSORIES

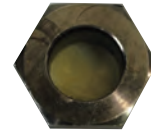

**NON REVERSE RATCHET ASSEMBLY PRICE**

**SIGHT GLASS LIST PRICE**

HP	Frame	Model Number	List Price	Weight (Lbs.)
10	215TP	NRR-215TP	\$433.00	13.0
15	254TP	NRR-250TP	\$771.00	32.0
20	256TP	NRR-250TP	\$771.00	32.0
25	284TP	NRR-280TP	\$771.00	32.0
30	286TP	NRR-280TP	\$771.00	32.0
40	324TP	NRR-320TP	\$888.00	43.2
50	326TP	NRR-320TP	\$888.00	43.2
60	364TP	NRR-360TP	\$888.00	43.2
75	365TP	NRR-360TP	\$888.00	43.2
100	404TP	NRR-400TP	\$1,162.00	70.1
125	405TP	NRR-400TP	\$1,162.00	70.1
150	444TP	NRR-445TP	\$1,848.00	99.7
200	445TP	NRR-445TP	\$1,848.00	99.7
250	445TP	NRR-445TP	\$1,848.00	99.7
300	5006P	NRR-5006P	\$3,512.00	169.5
350	5006P	NRR-5006P	\$3,512.00	169.5
400	5008P	NRR-5008P	\$3,512.00	169.5
450	5008P	NRR-5008P	\$3,512.00	169.5
500	5008P	NRR-5008P	\$3,512.00	169.5

HP	Frame	Model Number	List Price	Weight (Lbs.)
40	324TP	SG-320TP	\$35.00	0.15
50	326TP	SG-320TP	\$35.00	0.15
60	364TP	SG-360TP	\$35.00	0.15
75	365TP	SG-360TP	\$35.00	0.15
100	404TP	SG-400TP	\$65.00	0.33
125	405TP	SG-400TP	\$65.00	0.33
150	444TP	SG-445TP	\$65.00	0.33
200	445TP	SG-445TP	\$65.00	0.33
250	445TP	SG-445TP	\$65.00	0.33
300	5006P	SG-5006P	\$65.00	0.33
350	5006P	SG-5006P	\$65.00	0.33
400	5008P	SG-5008P	\$65.00	0.33
450	5008P	SG-5008P	\$65.00	0.33
500	5008P	SG-5008P	\$65.00	0.33



**TOP COVER LIST PRICE**

**ALTERNATIVE BASES LIST PRICE**

HP	Frame	Model Number	List Price	Weight (Lbs.)
10	215TP	TC-215TP	\$88.00	2.43
15	254TP	TC-250TP	\$120.00	2.54
20	256TP	TC-250TP	\$120.00	2.54
25	284TP	TC-280TP	\$120.00	2.54
30	286TP	TC-280TP	\$120.00	2.54
40	324TP	TC-320TP	\$160.00	2.87
50	326TP	TC-320TP	\$160.00	2.87
60	364TP	TC-360TP	\$168.00	3.97
75	365TP	TC-360TP	\$168.00	3.97
100	404TP	TC-400TP	\$195.00	5.18
125	405TP	TC-400TP	\$195.00	5.18
150	444TP	TC-445TP	\$225.00	7.28
200	445TP	TC-445TP	\$225.00	7.28
250	445TP	TC-445TP	\$225.00	7.28
300	5006P	TC-5006P	\$365.00	10.56
350	5006P	TC-5006P	\$365.00	10.56
400	5008P	TC-5008P	\$365.00	10.56
450	5008P	TC-5008P	\$365.00	10.56
500	5008P	TC-5008P	\$365.00	10.56

HP	Frame	Model Number	Base SIZE	List Price	Weight (Lbs.)
10	215TP	AB-215TP-10	10"	\$476.00	32.4
15	254TP	AB-250TP-12	12"	\$570.00	51.2
		AB-250TP-16.5	16.5"	\$570.00	51.2
20	256TP	AB-250TP-12	12"	\$570.00	51.2
		AB-250TP-16.5	16.5"	\$570.00	51.2
25	284TP	AB-280TP-12	12"	\$570.00	51.2
		AB-280TP-16.5	16.5"	\$570.00	51.2
30	286TP	AB-280TP-12	12"	\$570.00	51.2
		AB-280TP-16.5	16.5"	\$570.00	51.2
40	324TP	AB-320TP-12	12"	\$818.00	79.2
		AB-320TP-16.5	16.5"	\$818.00	79.2
50	326TP	AB-320TP-12	12"	\$818.00	79.2
		AB-320TP-16.5	16.5"	\$818.00	79.2
60	364TP	AB-360TP-12	12"	\$1,003.00	105.8
		AB-360TP-16.5	16.5"	\$1,003.00	105.8
75	365TP	AB-360TP-12	12"	\$1,003.00	105.8
		AB-360TP-16.5	16.5"	\$1,003.00	105.8
100	404TP	AB-400TP-16.5	16.5"	\$1,162.00	110.3
		AB-400TP-20	20"	\$1,162.00	110.3
125	405TP	AB-400TP-16.5	16.5"	\$1,162.00	110.3
		AB-400TP-20	20"	\$1,162.00	110.3
150	444TP	AB-445TP-16.5	16.5"	\$1,532.00	177.7
		AB-445TP-20	20"	\$1,532.00	177.7
200	445TP	AB-445TP-16.5	16.5"	\$1,532.00	177.7
		AB-445TP-20	20"	\$1,532.00	177.7
250	445TP	AB-445TP-16.5	16.5"	\$1,532.00	177.7
		AB-445TP-20	20"	\$1,532.00	177.7

# VHS MOTOR PERFORMANCE DATA

Model Number	VOLTAGE	HP	Speed	Frame	NEMA Code	Efficiency (%)	Power Factor	Torque (ft-lb)			Amps			Down Thrust (Lbs.)	DE Bearing	ODE Bearing	Insulation Class	Enclosure Type	Service Factor	Weight (Lbs)
								FLT	BDT (%)	LRT (%)	FLA	LRA								
NAE-VHS-10-4	230/460	10	1750	215TP	C	85.7	0.85	40.92	245%	195%	12.8	82.0	2500	6210	7310B	F	ODP	1.15	275	
NAE-VHS-15-4	230/460	15	1770	254TP	C	86.5	0.85	59.44	246%	203%	18.5	116.3	3200	6212	7312B	F	ODP	1.15	548	
NAE-VHS-20-4	230/460	20	1770	256TP	C	87.5	0.86	81.38	239%	194%	25.2	153.8	3200	6212	7312B	F	ODP	1.15	568	
NAE-VHS-25-4	230/460	25	1770	284TP	C	88.0	0.86	100.25	244%	203%	30.4	193.3	3200	6212	7312B	F	ODP	1.15	573	
NAE-VHS-30-4	230/460	30	1770	286TP	C	88.5	0.86	119.25	245%	211%	35.4	224.2	3200	6212	7312B	F	ODP	1.15	584	
NAE-VHS-40-4	230/460	40	1770	324TP	C	91.2	0.87	162.11	240%	214%	47.5	299.6	5500	6213	7221B	F	ODP	1.15	749	
NAE-VHS-50-4	230/460	50	1770	326TP	C	91.3	0.87	199.94	230%	195%	57.0	339.1	5500	6213	7221B	F	ODP	1.15	793	
NAE-VHS-60-4	230/460	60	1770	364TP	C	92.3	0.87	243.17	238%	190%	70.5	463.1	5600	6314	7224B	F	ODP	1.15	1031	
NAE-VHS-60-4-460V	460	60	1770	365TP	C	92.3	0.87	243.17	238%	190%	70.5	463.1	5600	6314	7224B	F	ODP	1.15	1031	
NAE-VHS-75-4	230/460	75	1770	365TP	C	92.3	0.87	297.21	251%	227%	86.0	591.1	5600	6314	7224B	F	ODP	1.15	1075	
NAE-VHS-75-4-460V	460	75	1770	404TP	C	92.3	0.87	297.21	251%	227%	86.0	591.1	5600	6314	7224B	F	ODP	1.15	1075	
NAE-VHS-100-4	230/460	100	1770	404TP	C	92.3	0.88	405.29	242%	215%	112.0	405.3	6700	6317	7230B	F	ODP	1.15	1399	
NAE-VHS-100-460V	460	100	1770	405TP	C	92.3	0.88	405.29	242%	215%	112.0	405.3	6700	6317	7230B	F	ODP	1.15	1399	
NAE-VHS-125-4	460	125	1780	405TP	C	93.2	0.88	483.69	245%	226%	133.9	875.0	6700	6317	7230B	F	ODP	1.15	1465	
NAE-VHS-150-4	460	150	1780	444TP	B	93.3	0.88	591.08	216%	176%	166.3	898.9	8000	6318	7232B	F	ODP	1.15	2004	
NAE-VHS-200-4	460	200	1780	445TP	B	93.8	0.88	806.02	243%	241%	224.6	1457.7	8000	6318	7232B	F	ODP	1.15	2115	
NAE-VHS-250-4	460	250	1780	445TP	C	93.8	0.88	994.09	200%	185%	278.3	1366.6	8000	6318	7232B	F	ODP	1.15	2225	
NAE-VHS-300-4	460	300	1780	5006P	C	94.8	0.89	1193.26	190%	170%	345.0	2001.0	14000	6322	7236B	F	ODP	1.15	2695	
NAE-VHS-350-4	460	350	1780	5006P	C	95.0	0.89	1392.13	190%	170%	403.0	2337.4	14000	6322	7236B	F	ODP	1.15	2800	
NAE-VHS-400-4	460	400	1780	5008P	C	95.3	0.89	1591.01	190%	170%	476.0	2760.8	24000	6322	7236B/DT	F	ODP	1.15	2855	
NAE-VHS-450-4	460	450	1780	5008P	C	95.4	0.89	1789.89	190%	170%	513.0	2975.4	24000	6322	7237B/DT	F	ODP	1.15	3280	
NAE-VHS-500-4	460	500	1780	5008P	C	95.5	0.89	1988.76	190%	170%	588.0	3410.4	24000	6322	7238B/DT	F	ODP	1.15	3375	

# VHS Dimensions

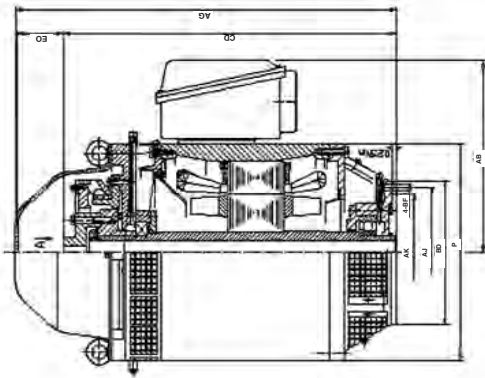
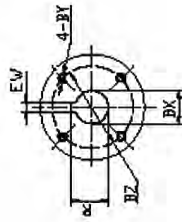
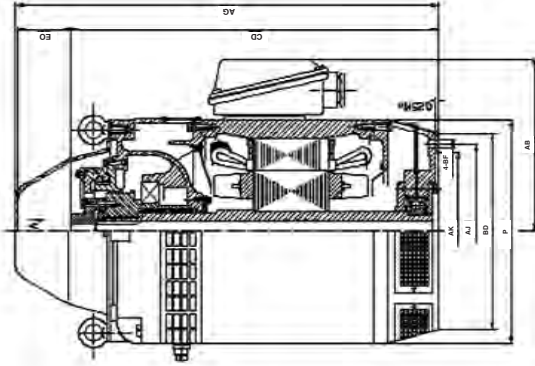

MODEL NUMBER	FRAME HP	BD	AJ	O AK	BF	BX	BZ	EW	R	BY	CD	E.O.	AC	AA	AF	Overall Dimensions				Angular Contact Bearing	Radial Ball Bearing
																P	AB	AG	AG		
NAE-VHS-10-4	215TP	10	9.125	8.25	0.44	1.00	1.38	0.250	1.130	10-32	17.56	3.74	8.58	NPT 1"	3.94	13.6	10.59	21.29	7310B	6210	
NAE-VHS-15-4	254TP	15	9.125	8.25	0.44	1.00	1.38	0.250	1.130	10-32	23.38	3.22	10.60	NPT 1-1/4"	3.98	13.6	14.06	26.8	7312B	6212	
NAE-VHS-20-4	256TP	20	9.125	8.25	0.44	1.00	1.38	0.250	1.130	10-32	23.38	3.22	10.60	NPT 1-1/4"	5.83	13.6	14.06	26.8	7312B	6212	
NAE-VHS-25-4	284TP	25	9.125	8.25	0.44	1.00	1.38	0.250	1.130	10-32	24.75	3.22	10.60	NPT 1-1/2"	5.83	15.2	14.06	28.1	7312B	6212	
NAE-VHS-30-4	286TP	30	9.125	8.25	0.44	1.00	1.38	0.250	1.130	10-32	24.75	3.22	10.60	NPT 1-1/2"	5.83	15.2	14.06	28.1	7312B	6212	
NAE-VHS-40-4	324TP	40	14.75	13.5	0.69	1.25	1.75	0.250	1.367	1/4-20	28.22	4.22	11.65	NPT 3"	5.83	17.3	15.07	32.7	7221B	6213	
NAE-VHS-50-4	326TP	50	14.75	13.5	0.69	1.25	1.75	0.250	1.367	1/4-20	28.22	4.22	11.65	NPT 3"	5.83	17.3	15.07	32.7	7221B	6213	
NAE-VHS-60-4	364TP	60	14.75	13.5	0.69	1.25	1.75	0.250	1.367	1/4-20	31.16	4.22	12.65	NPT 3"	5.83	19.1	15.90	36.0	7224B	6314	
NAE-VHS-75-4	365TP	75	14.75	13.5	0.69	1.25	1.75	0.250	1.367	1/4-20	31.16	4.56	12.56	NPT 3"	5.83	19.1	15.90	36.0	7224B	6314	
NAE-VHS-100-4	404TP	100	14.75	13.5	0.69	1.50	2.125	0.375	1.668	1/4-20	36.94	4.56	13.58	NPT 3"	5.83	21.0	17.00	42.2	7230B	6317	
NAE-VHS-125-4	405TP	125	14.75	13.5	0.69	1.50	2.125	0.375	1.668	1/4-20	36.94	4.56	13.58	NPT 3"	5.83	21.0	17.00	42.2	7230B	6317	
NAE-VHS-150-4	444TP	150	14.75	13.5	0.69	1.69	2.50	0.375	1.854	1/4-20	42.66	5.00	16.18	NPT 3"	7.56	23.3	20.70	47.7	7232B	6318	
NAE-VHS-200-4	445TP	200	14.75	13.5	0.69	1.69	2.50	0.375	1.854	1/4-20	42.66	5.00	16.18	NPT 3"	7.56	23.3	20.70	47.7	7232B	6318	
NAE-VHS-250-4	445TP	250	14.75	13.5	0.69	1.69	2.50	0.500	2.162	1/4-20	42.66	5.00	16.18	NPT 3"	7.56	23.3	20.70	47.7	7232B	6318	
NAE-VHS-300-4	5006P	300	14.75	13.5	0.688	1.688	2.50	0.375	2.162	1/4-20	49.75	7.82	22.25	2-NPT3"	9.05	29.125	27.375	57.75	7236B	6322	
NAE-VHS-350-4	5006P	350	14.75	13.5	0.688	1.688	2.50	0.375	2.162	1/4-20	49.75	7.82	22.25	2-NPT3"	9.05	29.125	27.375	57.75	7236B	6322	
NAE-VHS-400-4	5008P	400	14.75	13.5	0.688	1.938	2.50	0.50	2.162	1/4-20	53.88	7.82	22.25	2-NPT3"	9.05	29.125	27.375	61.875	7236B/DT	6322	
NAE-VHS-450-4	5008P	450	14.75	13.5	0.688	1.938	3.25	0.50	2.412	3/8-16	53.88	7.82	22.25	2-NPT3"	9.05	29.125	27.375	61.875	7237B/DT	6322	
NAE-VHS-500-4	5008P	500	14.75	13.5	0.688	2.188	3.25	0.50	2.412	3/8-16	53.88	7.82	22.25	2-NPT3"	9.05	29.125	27.375	61.875	7238B/DT	6322	

Toll Free: 800-884-0404 • www.naemotors.com • e-mail: sales@naemotors.com

# MODIFICATIONS AND SPECIAL BUILDS

North American Electric, Inc. can provide Vertical Hollow Shaft Motors manufactured or modified to your specification. Our Mod-Centers can modify standard motors to suit your special requirements usually within two weeks from the date you place your order. Modifications we offer include but are NOT limited to the following:

- 1.) Rerates: 6 & 8 Pole ratings in as little as two weeks.
- 2.) RTD's and BTD's installed.
- 3.) Special Paint.
- 4.) 175% EHT on 404TP, 405TP, 444TP, 445TP, 5006P and 5008P Frames.
- 5.) Steady Bushings installed.
- 6.) Non-Standard Coupling Bores.



## WIRING INFORMATION

### 12 Lead 230/460V Connections

12 Lead 230V Connection

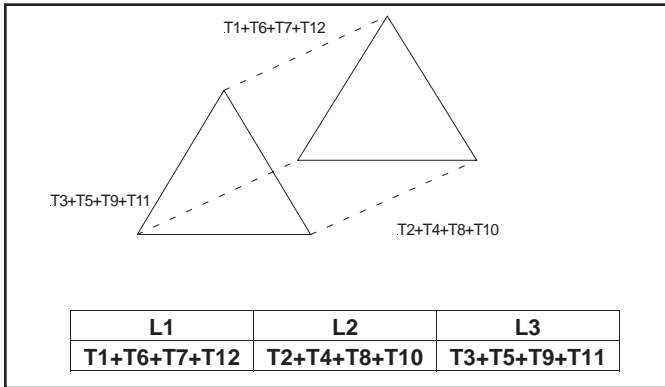

12 Lead 460V Connection

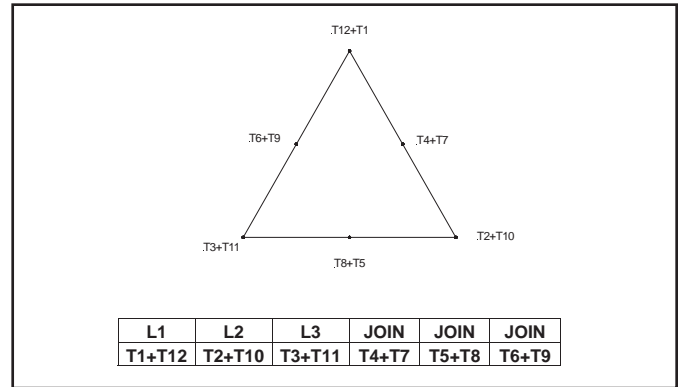

### 460V Only Connections

12 Lead 460V Only  
Across the Line Start Connection

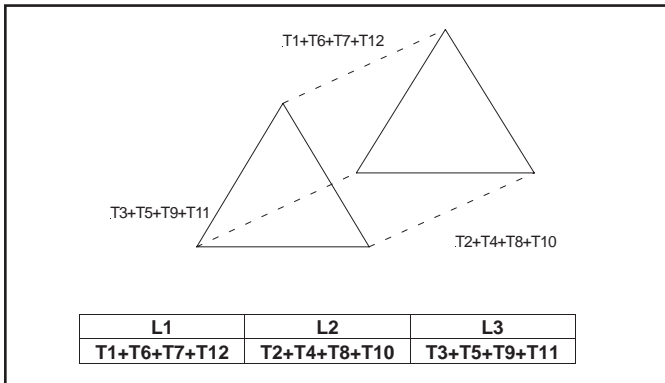

12 Lead 460V Only  
Part Wind Start Connection

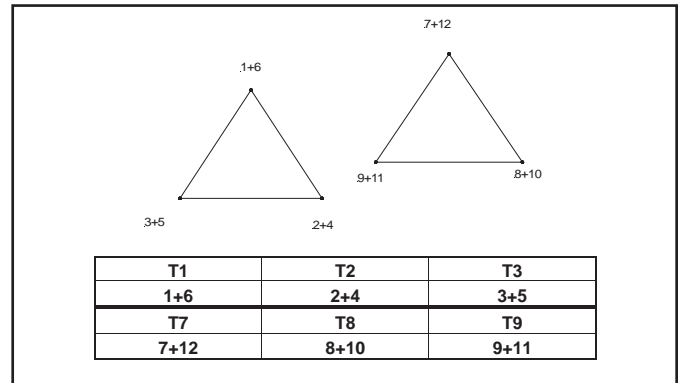



Data subject to change without notice

Distributed by:

North American Electric, Inc. • P.O. Drawer 130 • 350 Vaiden Drive • Hernando, MS 38632  
Toll Free: 800-884-0404 • Phone: 662-429-8049 • Fax: 662-429-8546 • Sales: 800-884-0405  
[www.naemotors.com](http://www.naemotors.com) • e-mail: [sales@naemotors.com](mailto:sales@naemotors.com)

